

Cassette Size	30"	38"	42"	48"	60"	68"	76"	85"	96"	108"	114"	120"
"A" (inch)	36	43.5	48	54	67	76	84.5	94	106	118	122	130
"B" (inch)	18	21.75	24	27	33.5	38	42.25	47	53	59	61	65
"C" (inch)	1.25	1.25	1.5	1.5	1.5	2	2	2	3	3	3	3
"D" (inch)	12	12	12.5	12.5	12.5	13.5	13.5	13.5	15.5	15.5	15.5	15.5
WEIGHT (lbs)	200	300	400	400	700	800	1000	1300	1600	2000	2200	2500

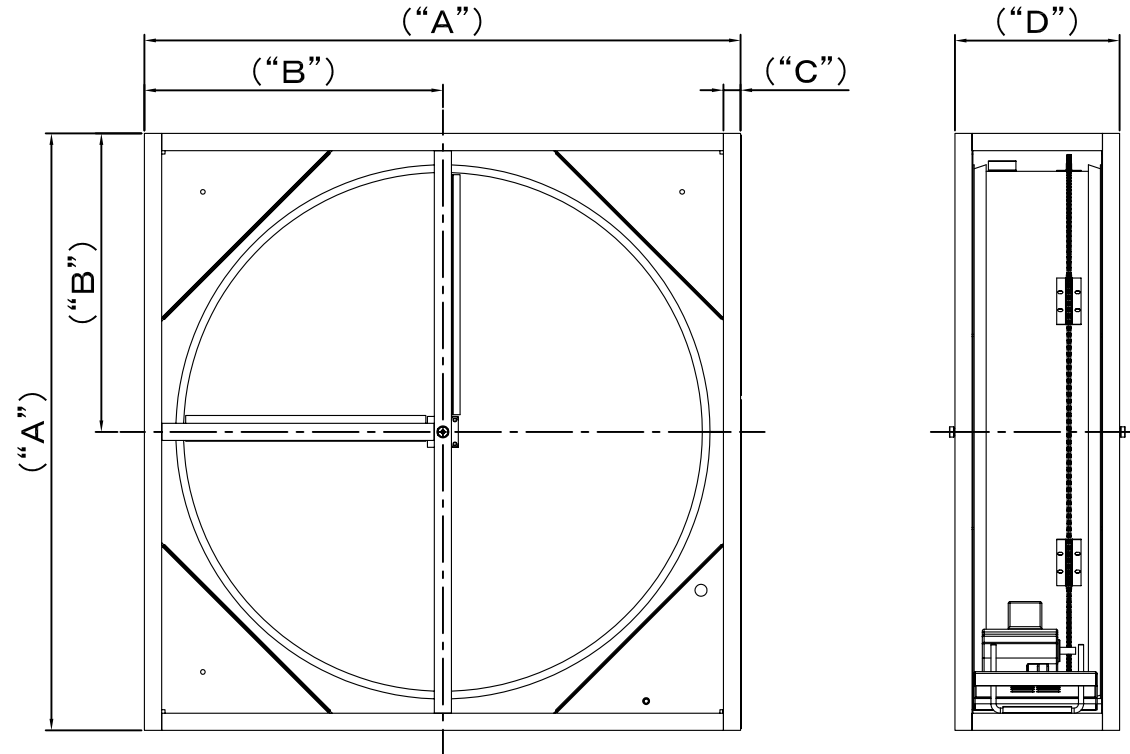

		REV	CONTENT&REASON	APPD	CHK	DFTG	DATE	
		TYPE DHC-	SET	CUST	MAN. NO.			
TITLE DEHUMIDIFIER CASSETTE ASS'Y						DWG. NO.		REV
SCALE NON	CHK	APPD						
DATE 2/16/10	DFTG Nobu							